

MARK INFRA HT

000000_R01



Read this document before installing the heater

1.0 General

Subject to change

The manufacturer is committed to constantly improving its products and reserves the right to make changes in the specifications without prior notice. The technical details are considered correct but do not form the basis for a contract or warranty. All orders are accepted according to the standard terms of our general sales and delivery conditions (available upon request). The information in this document is subject to change without notice. The most recent version of this manual is always available at www.markclimate.com/downloads.

1.1 General warnings



In case of gas smell : vent the ambient, do not start apparatus or electric switches, leave the building; then contact gas company and follow their instruction; if not possible, contact Firemen.

IMPORTANT: heaters **MUST NOT** be used in domestic environments. This unit will be devoted only to the use for which it was expressly provided, all other uses will be considered improper and therefore dangerous.

IMPORTANT : heaters **MUST NOT** be used in ambients with inflammable materials, liquids or vapours : non-compliance with these requirements may be cause of death, injury to persons or damage to things.

1.2 General instructions for installer, user and maintenance personnel

Thank you for having chosen MARK BV products !!! We are pleased to have You among our Customers, and we do think that use of our heaters will be fully satisfactory. To keep heaters perfectly working and safe, we ask you to follow the instructions of this handbook and to have all installation and maintenance operations carried out only by skilled personnel. In case of non-compliance with the following instructions, the warranty covering the products will be null and void.

IMPORTANT: This manual is an integral and essential to the product and must be delivered to the user. Please read the warnings contained in the manual before starting the installation as provide important information concerning the safety of installation, use and the necessary maintenance operations to be conducted over MARK BV heaters. Store carefully the manual for further consultations.

Installation should be done in accordance with the Regulations in force, as instructed by the Manufacturer and by professionally qualified staff; for professionally qualified staff means that having specific technical competence in the field of components plants and, in particular, the Technical Service Centres authorized by MARK BV. These devices must be installed only in premises with a sufficient ventilation. An incorrect installation can cause damage to people, animals and things, for which the Manufacturer is not responsible.

After you have removed any element of packing, ensure the integrity of the contents; in case

of doubt not use the equipment and contact the Manufacturer. The elements of packaging are potentially dangerous and therefore should not be left within the reach of children and must be disposed of according to regulations.

In case of failure and/or malfunction of the appliance, turn it off refraining from any attempt to repair or direct intervention; the eventual repair of products MARK BV should be performed only by an authorized Service Center by the Manufacturer using only original spare parts. In each case, call professionally qualified staff.

To ensure the efficiency of the appliance and for its proper functioning periodic maintenance is essential, performed by professionally qualified personnel, following the directions of Manufacturer. Before carrying out any operation or maintenance of cleanliness, wait for the unit is cold, disconnect the unit from the main power supply acting on the plant switch, close gas supply acting on cut-off devices. If the unit is equipped with accessories or modification kits (including electric) must be used genuine spare parts and accessories.

Failure to comply with the directions above may jeopardize the safety of the appliance.

When you decide to stop using the apparatus, will render harmless all parties that may be a source of potential danger. If the unit should be sold or transferred to another owner, always make sure this manual will accompany the equipment so that it can be consulted by the new user and / or maintainer.

It is excluded any contractual liability and extra-contractual the Manufacturer for damage caused by errors in the installation and use, and from non-compliance with the instructions given by the Manufacturer. The installation and maintenance must be carried out in accordance with regulations in the country of installation and the state of the art.

2.0 Plate label

Each unit is delivered complete with a plate of technical data, do not removable and placed at the head of the heater.

note - A1 apparatus, gas category II 2L3B

MARK BV
Beneden Verlaat 87-89
9645BM Veendam (NL)

Dit toestel moet door een bevoegd persoon in overeenstemming met de geldende regelgeving geïnstalleerd worden. Het toestel is alleen bedoeld voor ruimteverwarming in goed geventileerde ruimten. Niet gebruiken in kelders of ruimten beneden het maaiveld. Niet voor huishoudelijk gebruik of verwarmen van woongedeelten in woningen. Lees voor het installeren de bijgeleverde handleiding.

Model: **INFRA HT 16.2 eco** **CE 0694/08**
 Gascategorie: **I 2L3B / P**
 Pin code: **0694B.S0965**
 Land van bestemming : **NL**

Teestelcategorie :	A1	Opgenomen elektr. vermogen (W):	18
Nom. belasting MAX BW (kW):	26.0	Beschermingsklasse :	IP20
Nom. belasting MAX OW (kW):	23.4	Gassoort :	G25
Nom. belasting MIN BW (kW):	-	Gasvoerdruk (mbar):	25.0
Nom. belasting MIN OW (kW):	-	Branderdruk MAX (mbar):	14.0
Voltage (V):	230	Branderdruk MIN (mbar):	-
Frequentie (Hz):	50	Spuitsukdiameter (mm) :	4.30
		Gasverbruik MAX (m3/h) :	2.88
		Gasverbruik MIN (m3/h) :	-
		NOx categorie :	4

TOESTEL MAG NIET TOEGEPAST WORDEN IN EEN HUI SHOUDELIJKE OMGEVING

Plate label (exemple : Infra HT I 6.2 eco, G25 natural gas)

Essential features of the product are listed on the packaging label on the outside of the box.

mark **CE 0694**

MARK B.V.
Beneden Verlaat 87 - 89
9645 BM Veendam - HOLLAND

Radiant heater	MARK Infra HT 16.2 eco
MARK code nr.	: 59 99 004
Country destination	: NL
Heater category	: A1
Gas category	: I 2L3B / P
Gas type / gas pressure	: G 25 / 25 mbar

 Dit toestel moet door een bevoegd persoon in overeenstemming met de geldende regelgeving geïnstalleerd worden, EN 13410. Het toestel is alleen bedoeld voor ruimteverwarming in goed geventileerde ruimten. Niet gebruiken in kelders of ruimten beneden het maaiveld. Niet voor huishoudelijk gebruik of verwarmen van woongedeelten in woningen. Lees voor het installeren de bijgeleverde handleiding.

3.0 Warranty

MARK BV guarantees its products, whether installed by authorized personnel, for a period of 12 months from the date of the first start-up and no later than 18 months from the date of sale.

The warranty does not cover the components supplied by third parties, these are subject to the conditions of the original warranty.

The guarantee is only the free supply on Ex-Works basis, of parts with manufacturing or workmanship defects.

The guarantee does not cover disadvantages due to carelessness, incorrect setting, misuse of the unit or fortuitous accidents, and not dependent on imperfection processing or defective materials, and those due to dismantling or change without prior authorization from MARK BV.

The proper functioning of the apparatus depends on a proper installation and an start-up. Failure to comply with these rules immediately involves the decay of the guarantee, and therefore of responsibility by the manufacturer.

4.0 Technical data

4.1 Series "Infra HT.2" and "Infra HT.2 eco"

Model, series Infra HT.2		4.2	6.2	8.2	10.2	12.2	16.2	10+10.2	12+12.2	16+16.2
Weight, series Infra HT.2	(kg)	13	16	19	21	25	31	37	44	52
Model, series Infra HT.2 eco		4.2 e	6.2 e	8.2 e	10.2 e	12.2 e	16.2 e	10+10.2 e	12+12.2 e	16+16.2 e
Weight, series Infra HT.2 eco	(kg)	8	10	12	14	17	21	29	34	40
Number of ceramic plates	n°	4	6	8	10	12	16	20	24	32
Electric feeding		230 Volt - single phase - 50 Hz								
NOx class		4	4	4	4	4	4	4	4	4
GAS G20										
Heat input MAX (Hs)	(kW)	7.2	9.6	16.1	18.3	22.2	26.0	36.6	44.4	52.0
Heat input MAX (Hi)	(kW)	6.5	8.6	14.5	16.5	20.0	23.4	33.0	40.0	46.8
Heat input MIN (Hs)	(kW)	5.4	7.2	12.1	13.8	16.7	19.5	27.6	33.4	39.0
Heat input MIN (Hi)	(kW)	4.9	6.5	10.9	12.4	15.0	17.6	24.8	30.0	35.2
Gas supply pressure	(mbar)	20.0	20.0	20.0	20.0	20.0	20.0	20.0	20.0	20.0
Nozzle pressure MAX	(mbar)	15.5	14.0	14.0	15.0	16.0	14.0	15.0	16.0	14.0
Nozzle pressure MIN	(mbar)	8.5	7.5	8.0	9.0	9.5	8.0	9.0	9.5	8.0
Gas consumption MAX	(Sm ³ /h)	0.69	0.91	1.53	1.75	2.12	2.48	3.50	4.24	4.96
Gas consumption MIN	(Sm ³ /h)	0.52	0.69	1.15	1.31	1.59	1.86	2.62	3.18	3.72
Nozzle diameter	(mm)	2.10	2.45	3.10	3.30	3.50	3.90	2 x 3.30	2 x 3.50	2 x 3.90
GAS G25										
Heat input MAX (Hs)	(kW)	7.2	9.6	16.1	18.3	22.2	26.0	36.6	44.4	52.0
Heat input MAX (Hi)	(kW)	6.5	8.6	14.5	16.5	20.0	23.4	33.0	40.0	46.8
Heat input MIN (Hs)	(kW)	5.4	7.2	12.1	13.8	16.7	19.5	27.6	33.4	39.0
Heat input MIN (Hi)	(kW)	4.9	6.5	10.9	12.4	15.0	17.6	24.8	30.0	35.2
Gas supply pressure	(mbar)	25.0	25.0	25.0	25.0	25.0	25.0	25.0	25.0	25.0
Nozzle pressure MAX	(mbar)	13.7	14.0	14.5	16.0	16.0	14.0	16.0	16.0	14.0
Nozzle pressure MIN	(mbar)	8.3	7.5	8.5	9.5	9.5	8.0	9.5	9.5	8.0
Gas consumption MAX	(Sm ³ /h)	0.80	1.06	1.78	2.03	2.46	2.88	4.06	4.92	5.76
Gas consumption MIN	(Sm ³ /h)	0.60	0.80	1.34	1.53	1.85	2.17	3.06	3.70	4.34
Nozzle diameter	(mm)	2.30	2.70	3.40	3.60	3.80	4.30	2 x 3.60	2 x 3.80	2 x 4.30
GAS G30										
Heat input MAX (Hs)	(kW)	7.0	9.3	13.5	17.9	21.7	25.4	35.8	43.4	50.8
Heat input MAX (Hi)	(kW)	6.5	8.6	12.5	16.5	20.0	23.4	33.0	40.0	46.8
Heat input MIN (Hs)	(kW)	5.3	7.0	10.2	13.4	16.3	19.1	26.8	32.6	38.2
Heat input MIN (Hi)	(kW)	4.9	6.5	9.4	12.4	15.0	17.6	24.8	30.0	35.2
Gas supply pressure	(mbar)	30.0	30.0	30.0	30.0	30.0	30.0	30.0	30.0	30.0
Nozzle pressure MAX	(mbar)	28.2	28.0	28.0	28.5	28.1	27.5	28.5	28.1	27.5
Nozzle pressure MIN	(mbar)	16.5	16.0	15.5	16.0	16.0	16.5	16.0	16.0	16.5
Gas consumption MAX	(kg/h)	0.51	0.68	0.99	1.30	1.58	1.84	2.60	3.16	3.68
Gas consumption MIN	(kg/h)	0.39	0.51	0.74	0.98	1.18	1.39	1.96	2.36	2.78
Nozzle diameter	(mm)	1.30	1.50	1.80	2.10	2.30	2.45	2 x 2.10	2 x 2.30	2 x 2.45
GAS G31										
Heat input MAX (Hs)	(kW)	7.0	9.3	13.5	17.9	21.7	25.4	35.8	43.4	50.8
Heat input MAX (Hi)	(kW)	6.5	8.6	12.5	16.5	20.0	23.4	33.0	40.0	46.8
Heat input MIN (Hs)	(kW)	5.3	7.0	10.2	13.4	16.3	19.1	26.8	32.6	38.2
Heat input MIN (Hi)	(kW)	4.9	6.5	9.4	12.4	15.0	17.6	24.8	30.0	35.2
Gas supply pressure	(mbar)	37.0	37.0	37.0	37.0	37.0	37.0	37.0	37.0	37.0
Nozzle pressure MAX	(mbar)	36.2	35.7	35.7	36.2	36.2	35.7	36.2	36.2	35.7
Nozzle pressure MIN	(mbar)	22.0	20.0	20.0	20.0	20.5	20.0	20.0	20.0	20.5
Gas consumption MAX	(kg/h)	0.50	0.67	0.97	1.28	1.55	1.82	2.56	3.10	3.64
Gas consumption MIN	(kg/h)	0.38	0.50	0.73	0.96	1.16	1.37	1.92	2.32	2.74
Nozzle diameter	(mm)	1.30	1.50	1.80	2.10	2.30	2.45	2 x 2.10	2 x 2.30	2 x 2.45

4.2 Series “Infra HT.2 PIEZO” and “Infra HT.2 eco PIEZO”

Model, series Infra HT.2 PIEZO		4.2 PIEZO	6.2 PIEZO .	8.2 PIEZO .
Weight, series Infra HT.2 PIEZO	(kg)	13	16	19
Model, series Infra HT.2 eco PIEZO		4.2 eco PIEZO	6.2 eco PIEZO .	8.2 eco PIEZO .
Weight, series Infra HT.2 eco PIEZO	(kg)	8	10	12
Number of ceramic plates	n°	4	6	8
Electric feeding		NO		
NOx class		4	4	4
GAS G20				
Heat input MAX (Hs)	(kW)	7.2	9.6	16.1
Heat input MAX (Hi)	(kW)	6.5	8.6	14.5
Heat input MIN (Hs)	(kW)	-	-	-
Heat input MIN (Hi)	(kW)	-	-	-
Gas supply pressure	(mbar)	20.0	20.0	20.0
Nozzle pressure MAX	(mbar)	15.5	14.0	14.0
Nozzle pressure MIN	(mbar)	-	-	-
Gas consumption MAX	(Sm ³ /h)	0.69	0.91	1.53
Gas consumption MIN	(Sm ³ /h)	-	-	-
Nozzle diameter	(mm)	2.10	2.45	3.10
GAS G25				
Heat input MAX (Hs)	(kW)	7.2	9.6	16.1
Heat input MAX (Hi)	(kW)	6.5	8.6	14.5
Heat input MIN (Hs)	(kW)	-	-	-
Heat input MIN (Hi)	(kW)	-	-	-
Gas supply pressure	(mbar)	25.0	25.0	25.0
Nozzle pressure MAX	(mbar)	13.7	14.0	14.5
Nozzle pressure MIN	(mbar)	-	-	-
Gas consumption MAX	(Sm ³ /h)	0.80	1.06	1.78
Gas consumption MIN	(Sm ³ /h)	-	-	-
Nozzle diameter	(mm)	2.30	2.70	3.40
GAS G30				
Heat input MAX (Hs)	(kW)	7.0	9.3	13.5
Heat input MAX (Hi)	(kW)	6.5	8.6	12.5
Heat input MIN (Hs)	(kW)	-	-	-
Heat input MIN (Hi)	(kW)	-	-	-
Gas supply pressure	(mbar)	30.0	30.0	30.0
Nozzle pressure MAX	(mbar)	28.2	28.0	28.0
Nozzle pressure MIN	(mbar)	-	-	-
Gas consumption MAX	(kg/h)	0.51	0.68	0.99
Gas consumption MIN	(kg/h)	-	-	-
Nozzle diameter	(mm)	1.30	1.50	1.80
GAS G31				
Heat input MAX (Hs)	(kW)	7.0	9.3	13.5
Heat input MAX (Hi)	(kW)	6.5	8.6	12.5
Heat input MIN (Hs)	(kW)	-	-	-
Heat input MIN (Hi)	(kW)	-	-	-
Gas supply pressure	(mbar)	37.0	37.0	37.0
Nozzle pressure MAX	(mbar)	36.2	35.7	35.7
Nozzle pressure MIN	(mbar)	-	-	-
Gas consumption MAX	(kg/h)	0.50	0.67	0.97
Gas consumption MIN	(kg/h)	-	-	-
Nozzle diameter	(mm)	1.30	1.50	1.80

4.3 Series “Infra HT.2 DS”

Model Infra HT.2 DS		4.2 DS	6.2 DS	8.2 DS	10.2 DS	12.2 DS
Number of ceramic plates	n°	4	6	8	10	12
Electric feeding		230 Volt - single phase - 50 Hz				
Weight, series Infra HT.2 DS	(kg)	11	13	15	17	19
NOx class		4	4	4	4	4
GAS G20						
Heat input MAX (Hs)	(kW)	7.2	9.6	16.1	18.3	22.2
Heat input MAX (Hi)	(kW)	6.5	8.6	14.5	16.5	20.0
Heat input MIN (Hs)	(kW)	5.4	7.2	12.1	13.8	16.7
Heat input MIN (Hi)	(kW)	4.9	6.5	10.9	12.4	15.0
Gas supply pressure	(mbar)	20.0	20.0	20.0	20.0	20.0
Nozzle pressure MAX	(mbar)	15.5	14.0	14.0	15.0	16.0
Nozzle pressure MIN	(mbar)	8.5	7.5	8.0	9.0	9.5
Gas consumption MAX	(Sm ³ /h)	0.69	0.91	1.53	1.75	2.12
Gas consumption MIN	(Sm ³ /h)	0.52	0.69	1.15	1.31	1.59
Nozzle diameter	(mm)	2.10	2.45	3.10	3.30	3.50
GAS G25						
Heat input MAX (Hs)	(kW)	7.2	9.6	16.1	18.3	22.2
Heat input MAX (Hi)	(kW)	6.5	8.6	14.5	16.5	20.0
Heat input MIN (Hs)	(kW)	5.4	7.2	12.1	13.8	16.7
Heat input MIN (Hi)	(kW)	4.9	6.5	10.9	12.4	15.0
Gas supply pressure	(mbar)	25.0	25.0	25.0	25.0	25.0
Nozzle pressure MAX	(mbar)	13.7	14.0	14.5	16.0	16.0
Nozzle pressure MIN	(mbar)	8.3	7.5	8.5	9.5	9.5
Gas consumption MAX	(Sm ³ /h)	0.80	1.06	1.78	2.03	2.46
Gas consumption MIN	(Sm ³ /h)	0.60	0.80	1.34	1.53	1.85
Nozzle diameter	(mm)	2.30	2.70	3.40	3.60	3.80
GAS G30						
Heat input MAX (Hs)	(kW)	7.0	9.3	13.5	17.9	21.7
Heat input MAX (Hi)	(kW)	6.5	8.6	12.5	16.5	20.0
Heat input MIN (Hs)	(kW)	5.3	7.0	10.2	13.4	16.3
Heat input MIN (Hi)	(kW)	4.9	6.5	9.4	12.4	15.0
Gas supply pressure	(mbar)	30.0	30.0	30.0	30.0	30.0
Nozzle pressure MAX	(mbar)	28.2	28.0	28.0	28.5	28.1
Nozzle pressure MIN	(mbar)	16.5	16.0	15.5	16.0	16.0
Gas consumption MAX	(kg/h)	0.51	0.68	0.99	1.30	1.58
Gas consumption MIN	(kg/h)	0.39	0.51	0.74	0.98	1.18
Nozzle diameter	(mm)	1.30	1.50	1.80	2.10	2.30
GAS G31						
Heat input MAX (Hs)	(kW)	7.0	9.3	13.5	17.9	21.7
Heat input MAX (Hi)	(kW)	6.5	8.6	12.5	16.5	20.0
Heat input MIN (Hs)	(kW)	5.3	7.0	10.2	13.4	16.3
Heat input MIN (Hi)	(kW)	4.9	6.5	9.4	12.4	15.0
Gas supply pressure	(mbar)	37.0	37.0	37.0	37.0	37.0
Nozzle pressure MAX	(mbar)	36.2	35.7	35.7	36.2	36.2
Nozzle pressure MIN	(mbar)	22.0	20.0	20.0	20.0	20.5
Gas consumption MAX	(kg/h)	0.50	0.67	0.97	1.28	1.55
Gas consumption MIN	(kg/h)	0.38	0.50	0.73	0.96	1.16
Nozzle diameter	(mm)	1.30	1.50	1.80	2.10	2.30

note – the unit “Infra HT 10.2 DS” is NOT in production yet

5.0 Installation

5.1 Ventilation of the ambients



IMPORTANT: heaters must be installed in well-ventilated and manned ambients, in compliance with current legislation

The unit leaves the combustion products into the environment in which it is used (equipment type AI). It is therefore necessary to ensure ventilation and air changes of the premises in which the heater is installed, realizing appropriate air outlet openings on the perimeter walls of the same, or creating a system of mechanical ventilation. To ensure a sufficient air change, the flow of air needed can be calculated using the following equation (UNI EN 13410):

$$V_{\text{tot}} = \sum Q_{\text{nb}} \times L$$

Where :

- V_{tot} = air change flow rate in m³/h
- $\sum Q_{\text{nb}}$ = total heating power installed in the premises in kW
- L = air change coefficient (must be ≥ 10 m³ /h / kW)

IMPORTANT: air change coefficient “L” to be used **MUST NOT** be lower than 10 m³/h for each kW of installed power.

For **NO** reason the heaters can be installed :

- in ambients used as residential ambient
- in rooms smaller than 12 m³
- where wind speed is higher than 2 m/s

5.2 Positioning of the radiant heater

The heaters can be installed on walls / pillars, or hanging at ceiling. On request, we can provide supports (S hooks and chains are excluded) for suspension at ceiling (picture 1), or wall brackets to fix the heaters on the wall (picture 2) with different angled positions for the heater. The following figures will show you how to install all types of heaters.



picture 1 – with chains series **Infra HT.2**

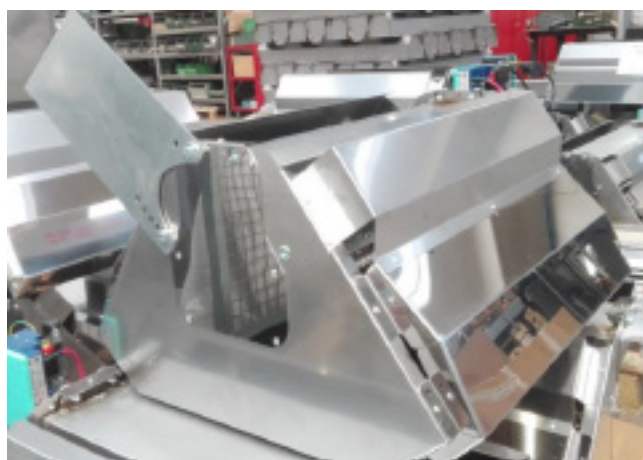

picture 2 – at wall series **Infra HT.2**



picture 1 – with chains series **Infra HT.2 eco**

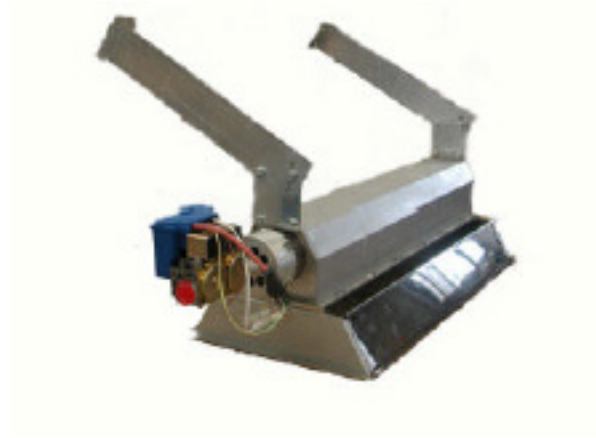

picture 2 – at wall series **Infra HT.2 eco**



picture 1 – with chains series **Infra HT.2 DS**



picture 2 – at wall series **Infra HT.2 DS**

The brackets provided by MARK BV allow an angle of installation variable once mounted on a wall or pillar, in order to get a better heat distribution (picture 2.1 shows supports for units type Infra HT.2 eco, Infra HT.2 eco PIEZO and Infra HT.2 DS)



picture 2.1 – different angles available

IMPORTANT:

- At each side of the burner 2 hooks are provided with M8 inserts, for fixing to a wall or at ceiling by means of appropriate brackets (not supplied, available on request); do not create other anchor points on the carpentry of the heater and in particular on the body burner, but use only those designed by the factory
- We recommend MARK BV original brackets for installation of the radiant heaters
- For fixing brackets on a wall or pillars assess the consistency of walls and the load applied, in order to choose the correct anchors to be used; in any case provide blocks with M8 screw minimum diameter (e.g. anchor Fischer TA - M in steel, with M8 screw)

- The equipment must be installed in **horizontal position**.
- In any case, the system of fixing / suspension must allow the thermal expansion of appliance (some millimeter depending on the model).

5.3 Handling

From unpacking to placing the products at the installation site, gas valves/flame arresters or spray unit flanges must NOT be used as lifting points (as shown in the figures below).

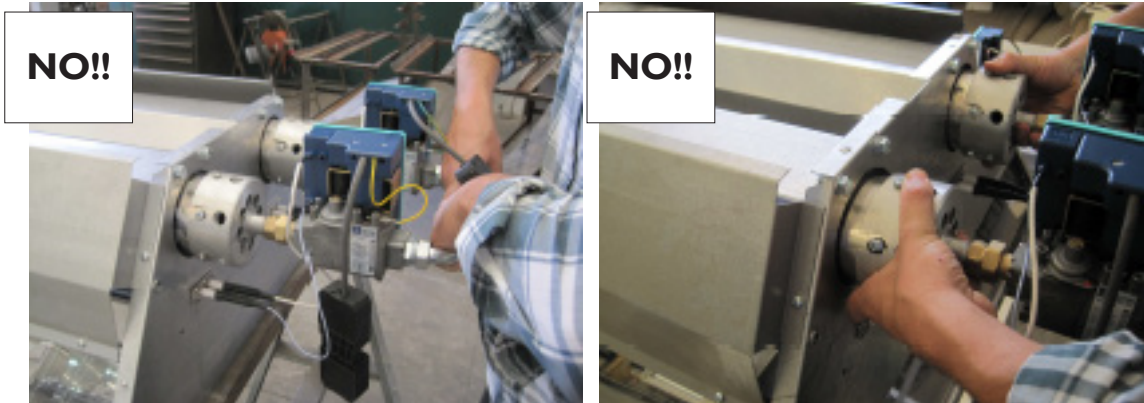

The product must be brought to the installation point/height in its packaging or using M8 inserts: all other parts of the product are NOT designed to support its weight.

5.4 MINIMUM height of installation (for people comfort)

The indicative heights for the installation of heaters are as follows :

MODEL	HEIGHT of INSTALLATION (mt)	
	MIN	MAX
Infra HT 4.2 PIEZO ; Infra HT 4.2 eco PIEZO	2.5	4.5
Infra HT 6.2 PIEZO ; Infra HT 6.2 eco PIEZO	3.5	5.0
Infra HT 8.2 PIEZO ; Infra HT 8.2 eco PIEZO	4.0	6.0
Infra HT 4.2 ; Infra HT 4.2 eco ; Infra HT 4.2 DS	2.5	4.5
Infra HT 6.2 ; Infra HT 6.2 eco ; Infra HT 6.2 DS	3.5	5.0
Infra HT 8.2 ; Infra HT 8.2 eco ; Infra HT 8.2 DS	4.0	6.0
Infra HT 10.2 ; Infra HT 10.2 eco ; Infra HT 10.2 DS	5.0	7.0
Infra HT 12.2 ; Infra HT 12.2 eco ; Infra HT 12.2 DS	6.0	8.0
Infra HT 16.2 ; Infra HT 16.2 eco	7.0	9.0
Infra HT 10+10.2 ; Infra HT 10+10.2 eco	8.0	11.0
Infra HT 12+12.2 ; Infra HT 12+12.2 eco	9.0	14.0
Infra HT 16+16.2 ; Infra HT 16+16.2 eco	10.0	18.0

Height “MIN” means the minimum distance at which the equipment should be installed so that people who are in radiated zone, are not subject to excessive heat.

Quotes relate to equipment installed in horizontal position for heaters with angled position (15 ÷ 45°); the minimum height can be reduced roughly between a 5% (15 ° angle) and a 20% (45 ° angle).

Shares relate to installation with ambient temperature of 10 ÷ 12 °C; in case of ambients with higher or lower temperatures the minimum height of installation must be reviewed; consider a reduction of 5% (for temperatures lower of approx. 5 ° C) or increase of 5% (for temperatures higher of approx. 5 ° C).

Above heights of installation are indicative, consult us each case to select the correct unit and the best height of installation (in particular for limit values).

5.5 MINIMUM distances from flammable surfaces

IMPORTANT: The flammable materials inside the radiation could begin to burn and cause fires.



Surfaces Close To Heaters Must Be Done In Material Of Class 'a0' With Respect To Fire Response (Not Combustible And Not Inflammable) And With Degree Of Resistance To Fire Equal Or More Than "Rei 90"

Minimum distances of installation must be respected between the heating surface of the heater and the adjacent walls, inside the area of radiation and outside, if they are not protected against radiation or are flammable materials; in case below minimum distances can not be met, consider to mount screens for the heat.

Pay special attention also in cases of installing heaters above craneways.

The MINIMUM distances are as follows :

MODEL	MINIMUM distance (mt) between heater and ...			
	Ceiling	Floor	Front	Sides
Infra HT 4.2 PIEZO ; Infra HT 4.2 eco PIEZO	1.0	2.0	1.0	1.0
Infra HT 6.2 PIEZO ; Infra HT 6.2 eco PIEZO	1.0	2.5	1.0	1.0
Infra HT 8.2 PIEZO ; Infra HT 8.2 eco PIEZO	1.5	3.0	1.5	1.5
Infra HT 4.2 ; Infra HT 4.2 eco ; Infra HT 4.2 DS	1.0	2.0	1.0	1.0
Infra HT 6.2 ; Infra HT 6.2 eco ; Infra HT 6.2 DS	1.0	2.5	1.0	1.0
Infra HT 8.2 ; Infra HT 8.2 eco ; Infra HT 8.2 DS	1.5	3.0	1.5	1.5
Infra HT 10.2 ; Infra HT 10.2 eco ; Infra HT 10.2 DS	1.5	3.5	1.5	1.5
Infra HT 12.2 ; Infra HT 12.2 eco ; Infra HT 12.2 DS	1.5	4.0	2.0	1.5
Infra HT 16.2 ; Infra HT 16.2 eco	1.5	4.5	2.0	1.5
Infra HT 10+10.2 ; Infra HT 10+10.2 eco	2.0	5.0	2.5	2.0
Infra HT 12+12.2 ; Infra HT 12+12.2 eco	2.0	5.5	2.5	2.0
Infra HT 16+16.2 ; Infra HT 16+16.2 eco	2.0	6.0	2.5	2.0

NOTE – contact us in case of different quotes or special cases

5.6 Connection to gas supply

IMPORTANT: hydraulic connection of the heater to the gas distribution net must be made according to information given in this technical book exclusively by professionally qualified staff

The heaters are provided according to the type of gas chosen, and then before making the connection to the power network of gas, make sure that the gas used corresponds to what is shown on the data plate label of the unit. Before connection to the gas pipeline, make sure that the pipes are properly cleaned and produced in accordance with regulations in force in the country of installation.

NOTE : provide a fuel interception tap in the vicinity of the heater, and with easily accessible position; make the connection between the heater and the gas network using an approved steel flexible pipe.

Once the connection is made, in compliance with the rules in force in the country of installation, a) verify the sealing of hydraulic pipes and gas connection to the unit, b) check that the pressure is correct, c) make sure that the apparatus functions in the conditions for which it was prepared.

- Models Infra HT.2 , Infra HT.2 eco and Infra HT.2 DS : the connection is 1/2" gas. The models

Infra HT.2, Infra HT.2 eco and Infra HT.2 DS are equipped with a multifunctional group composed of double seat valve fitted with pressure stabilizer and integrated flame control. The stabilizer accepts a maximum inlet pressure of 50 mbar and the valve is equipped with a pressure intakes, to measure and control incoming and outgoing pressures.

- Models Infra HT.2 PIEZO and Infra HT.2 eco PIEZO : the connection is 3/8" gas. The Infra HT.2 PIEZO and Infra HT.2 eco PIEZO models are equipped with valve tap, pressure stabilizer for a maximum inlet pressure of 50 mbar, and pressure intake at the nozzle.

NOTE : all units are supplied already tested and set to the properly operating pressure; therefore DO NOT remove seals, DO NOT change the values (expiring of guarantee !!!)



IMPORTANT: the feeding gas pipeline must be kept at a distance of at least 1 m from the zone of discharge of the combustion products and must not be exposed all'irraggiamento direct irradiation of heaters

5.7 Connection to electric supply (only for units with flame control)



IMPORTANT: the electrical connection of the equipment shall be made in accordance with the directions given in this technical book exclusively by professionally qualified personnel. The installation must be carried out in accordance with regulations in the country of installation.

The heater must be fed with 230V / Single Phase / 50Hz voltage. The control flame mounted on gas valve has a plug/socket connection with security hook (picture 3). Mount a bipolar switch upstream of the heater for switch-on and switch-off, so you can isolate it from electric supply. Use this manual for the size of the power supply line, or refer to the data given in the plate label of the heater. In any case, for ON-OFF version use a cable 3x1.5mm² minimum section. The wiring diagrams are shown on page 20 (ON-OFF version) and page 23 (H/L = TWO-STAGES version) of this manual.

For the electrical connection unlock the plug and unscrew its case; connect a tri-polar cable according to the indications given on the terminal plug, namely:

L1 = phase wire

N = neutral wire



= earth wir

L2 = modulator command for H/L = two-stages gas valve (if provided)

L3 = signal for burner block (if provided)



IMPORTANT: It is essential for the smooth functioning of the heater, to respect the Phase / Neutral polarity of the network, with one indicated on the power connector.

It is also essential for the smooth functioning of the appliance, and for the safety of the user, an efficient plant earthing, executed according to existing regulations. Under no circumstances you can use the conduit connection of gas as earthing of equipment.

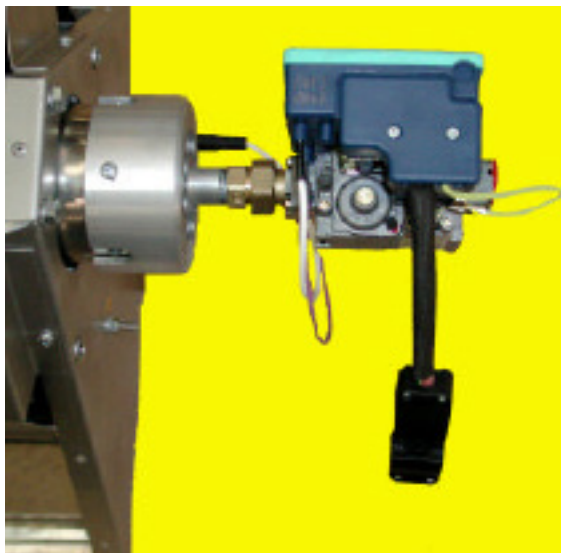

Picture 3 – Connector for electric connection

6.0 Wiring Diagram

6.1 "SIT" control unit ON-OFF

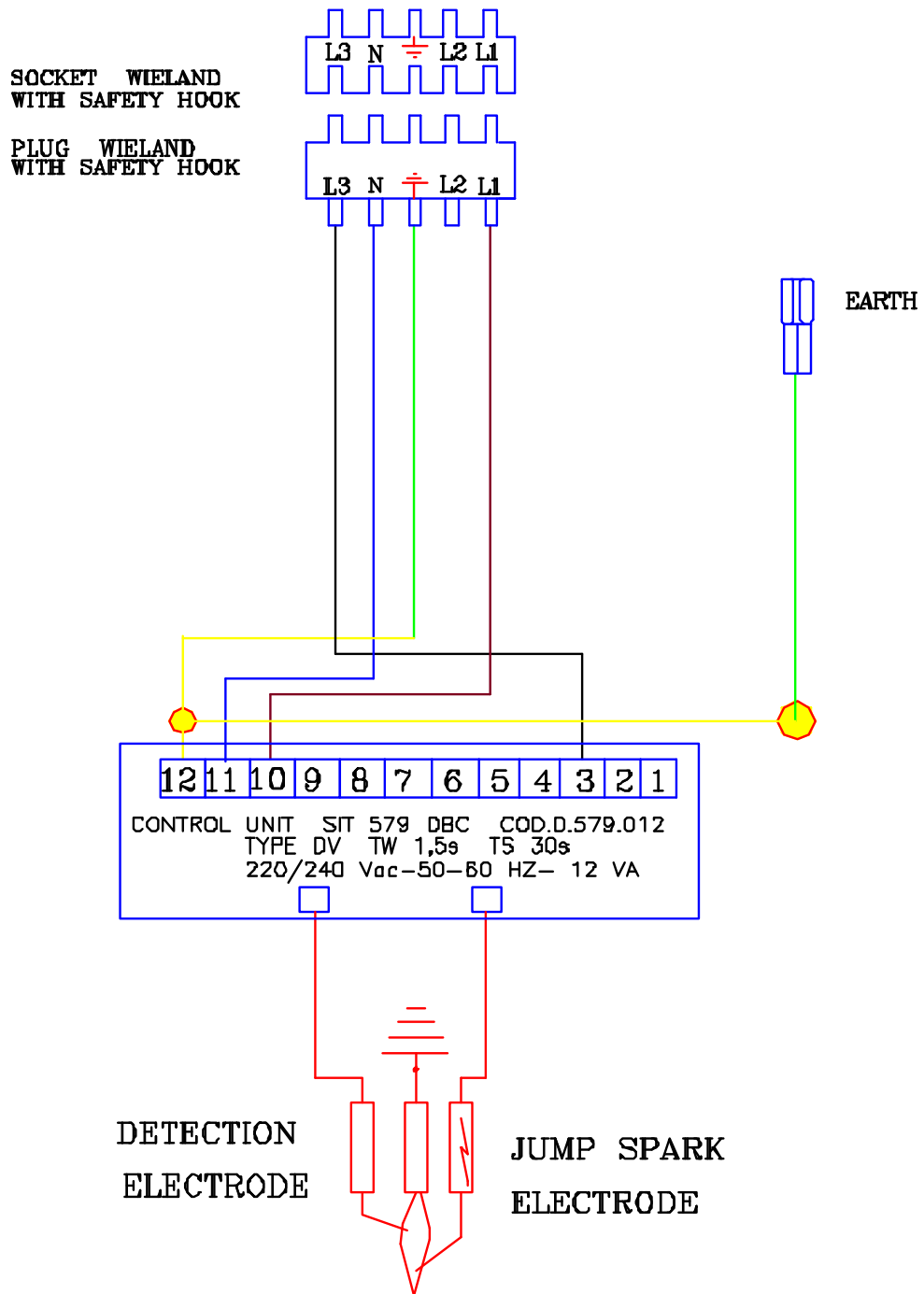

LEGEND

- L1 = BROWN, PHASE WIRE
- L2 = CONTACT for TWO-STAGES VERSION (if provide)
- L3 = BLACK, ALARM for BURNER BLOCK 220Volt (if provided)
- N = BLUE, NEUTRAL WIRE
- ↓ = YELLOW/GREEN, EARTH WIRE

6.2 "SIT" control unit H/L = TWO-STAGES

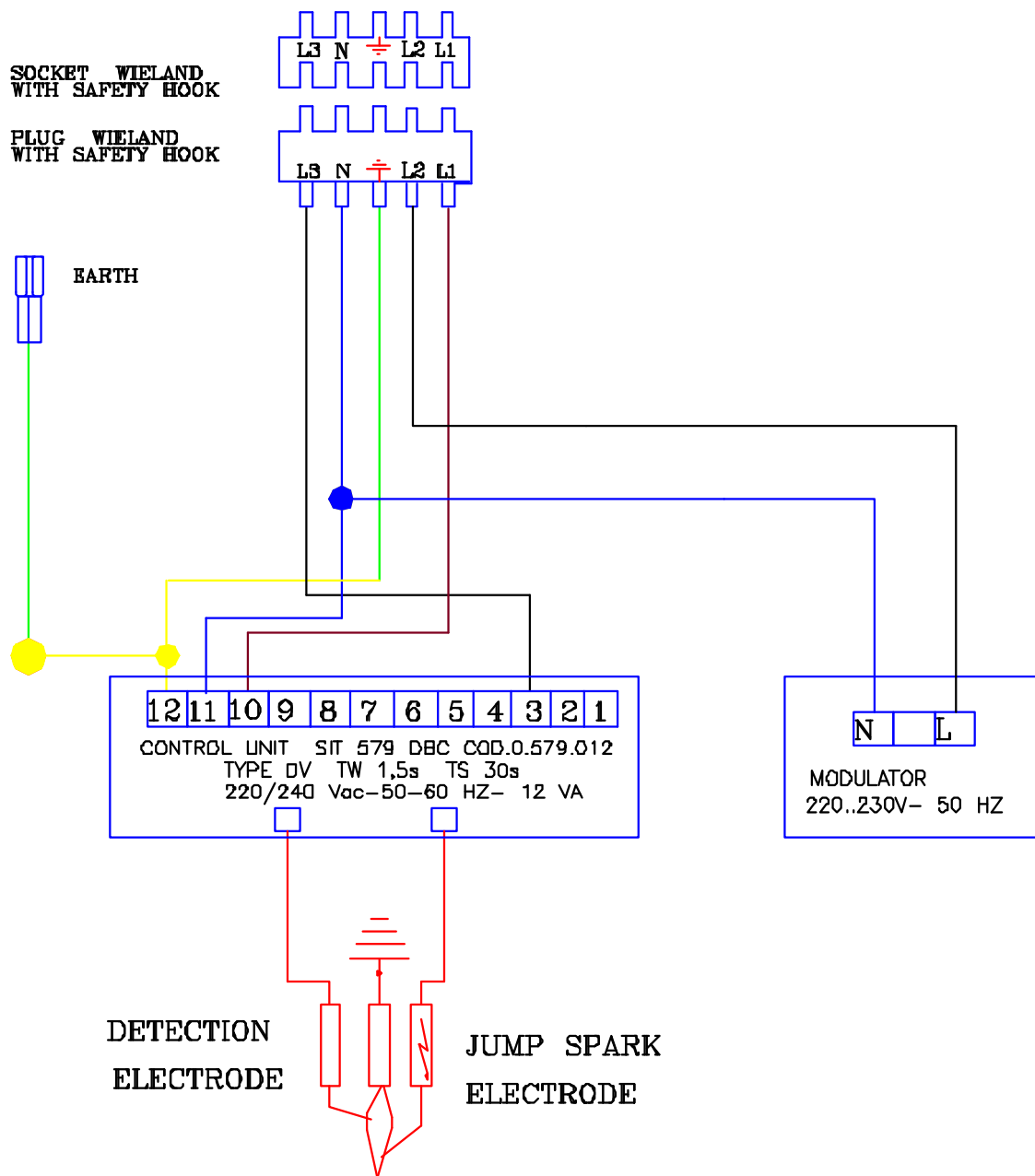

LEGEND

- L1 = BROWN, PHASE WIRE
- L2 = CONTACT for TWO-STAGE VERSION
- L3 = BLACK, ALARM for BURNER BLOCK 220Volt (if provided)
- N = BLUE, NEUTRAL WIRE
- ⬇ = YELLOW/GREEN, EARTH WIRE

6.3 NOTE for SIT “HIGH / LOW” gas valve = two-stages

NOTE: the “HIGH / LOW ” version must be equipped with a specific switch for pressure modulator feeding, to be placed in the main electric switchboard.

Modulator fed: HIGH pressure running
Modulator NOT fed: LOW pressure running

IMPORTANT: start-up of the heater must always take place with the modulator fed (HIGH pressure running).

You will find the data (heat input, pressure and gas flow rate) referring to the apparatus with H/L = TWO-STAGES version, in the tables of this manual (chapter 4: technical data).

The H/L = TWO-STAGES version allows :

- save on gas consumption
- better confort condition for people
- lower number of start-up / switch-off of the heater

6.4 Setting of the pressure

Unscrew the screw of the PO pressure intake of the gas valve before the nozzle (pictures 1.A and 1.B), and connect a water column manometer. Feed the modulator and take out the yellow tap of the pressure regulator. Act, as shown in picture 2, on the CH10 screw for setting of the maximum pressure, till you get the required pressure. Take out tension at the pressure modulator, and with a screw-driver act on the inner screw for minimum setting (picture 3) till you get the required pressure.

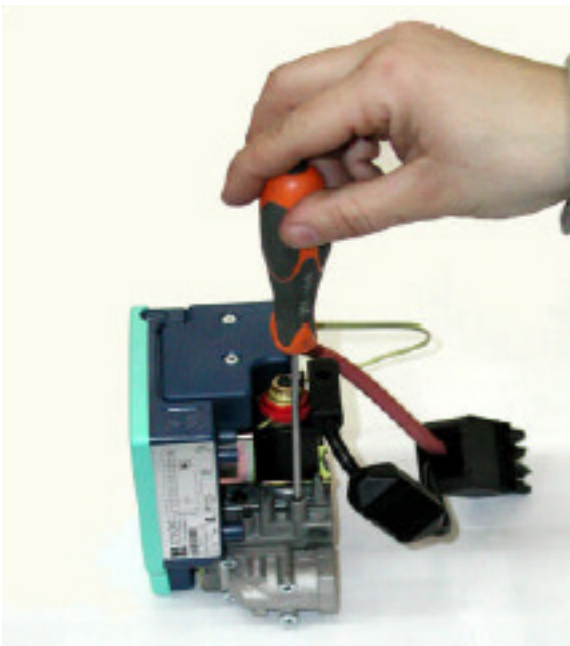

Picture 1.A



Picture 1.B



Picture 2



Picture 3

6.5 Gas group (gas valve and flame protection)

There are 3 different options:

A_products with 1 burner (models Infra HT 4.2, Infra HT 6.2, Infra HT 8.2, Infra HT 10.2, Infra HT 12.2 and Infra HT 16.2)

These are equipped with 1 gas valve and 1 flame protection

B_products with 2 burners (models Infra HT 10+10.2, Infra HT 12+12.2 and Infra HT 16+16.2)

Products with 2 burners are equipped with 2 gas valves and 2 flame protections.

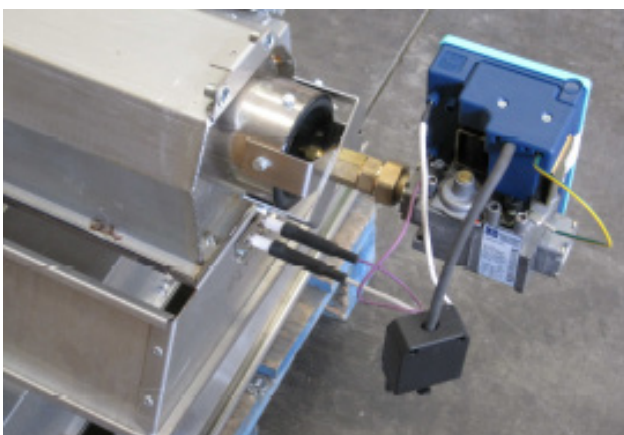

A

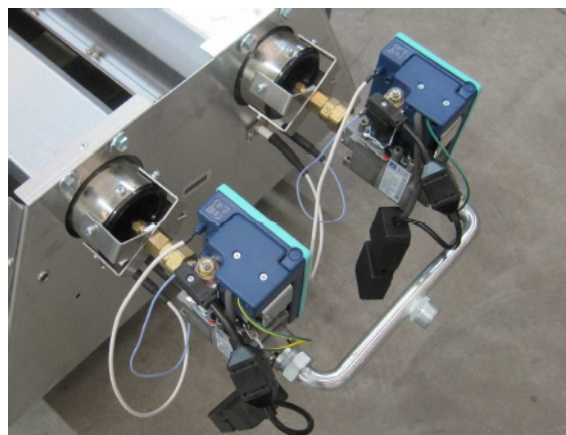

B

7.0 Put in operation and first start-up

When the first ignition of heater is important to do some preliminary checks to ensure proper operation of the unit. The operations listed below are considered essential for its safe operation.

- Make sure there are no losses in the gas line and that is properly sized
- Check that the pressure of fuel and type of gas used comply with the provisions on the plate of the characteristics of the heater
- Check the proper installation of gas valve / control flame group (only models Infra HT.2, Infra HT.2 eco and Infra HT.2 DS)
- Check that the power electric line has been correctly sized, which has been respected phase - neutral polarity and that the cable earthing is connected (only models Infra HT.2, Infra HT.2 eco and Infra HT.2 DS)
- Make sure the mechanical installation (supports) of the heater have been properly carried out and that the connections bolts are tight
- Use only steel materials, since heat is transferred from heaters to supports

7.1 Units with electronic control unit (Infra HT.2, Infra HT.2 eco and Infra HT.2 DS)

For the heaters with an ignition system and electronic control flame, the start-up sequence includes the following phases:

- Giving tension to the heater, ignition electrode begins sparking, and the gas valve opens
- The sparking electrode ends after 30 seconds
- In the case has not been detected the presence of flame, control flame goes into block after 30 seconds. For re-start it is necessary to remove tension for a period of not less than 20 seconds: after that period of time, the start-up sequence can be repeated. If the heater continues going into block, refer to the section 'Maintenance' of this manual
- Switch-off of the heater is done by taking out power supply to control unit



IMPORTANT: at time of first start-up of the heater, pressure setting has to be checked, then must be sealed the body of pressure regulator of gas valve

So, must perform the following procedure (picture 4) :

- Unscrew the screw of intake pressure, upstream at the nozzle (PO) and connect a suitable gauge
- Remove the cap of pressure regulator (R) and act, as shown in picture 4, on the screw of adjustment till match up to the pressure gauge reading with that stated on plate on the characteristics
- Disconnect the pressure gauge and close the screw of intake pressure (PO)
- Reassemble the cap of the regulator (R) and place a suitable seal

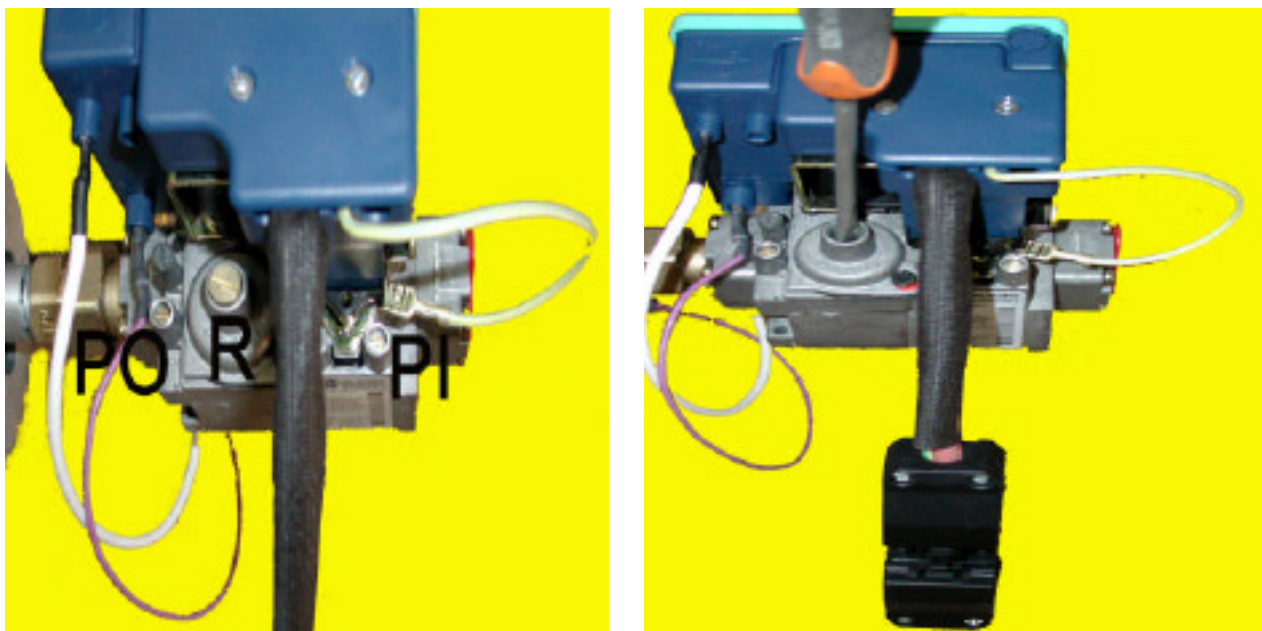

Picture 4 – Setting of working pressure for models Infra HT.2, Infra HT.2 eco and Infra HT.2 DS with “SIT” valve

7.2 Units with manual start-up (Infra HT.2 PIEZO and Infra HT.2 eco PIEZO)

For the heaters with an ignition system and electronic control flame, the start-up sequence includes the following phases:

The sequence of ignition for heaters with manual start-up system / piezo (picture 5) is :

- Press the button of gas valve
- Simultaneously push the button of the piezo starter until ignition occurred
- Hold the button of the valve about 10sec. or until the activation of electromagnetic part of the thermocouple
- Switch-off of the heater is done simply by closing the gas feeding



picture 5 – start-up for models Infra HT.2 PIEZO and Infra HT.2 eco PIEZO



IMPORTANT: at time of first start-up of the heater, pressure setting has to be checked, then must be sealed the body of pressure regulator of the stabilizer.

So, must perform the following procedure (picture 5) :

- Unscrew the screw of the intake pressure, upstream at the nozzle POM and connect a suitable

gauge

- Remove the cap of the pressure regulator RM and act as shown in picture 6, on the screw of adjustment till match up to the pressure gauge reading with that stated on plate on the characteristics
- Disconnect the pressure gauge and close the screw of the intake pressure POM
- Reassemble the cap of the regulator RM and place a suitable seal

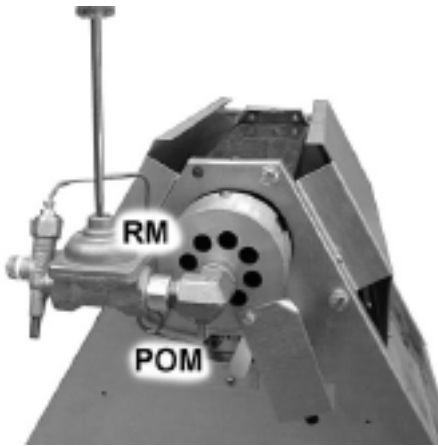

picture 6 – Setting of working pressure for models Infra HT.2 PIEZO and Infra HT.2 eco PIEZO

8.0 Maintenance

An appropriate use of the heaters, plus their proper and regular maintenance are essential to ensure better performance and longer working life to the heater.



IMPORTANT: before making any routine maintenance, make sure that both the gas and the power supply have been excluded, and that the apparatus is cold. For all routine and / or extraordinary maintenance, contact only professionally qualified staff, or rather a Technical Assistance Centre authorized by MARK BV.

At least once a year before the season of use, it is strongly advisable to perform an intervention for control / inspection and cleaning:

- Visual inspection of radiant surface (if any cracked ceramic plate)
- Cleaning of radiant surface with compressed air at LOW PRESSURE from inside
- Nozzle cleaning
- Electrodes cleaning, correct position and efficiency sparking
- Check of keeping all the electrical connections
- Search for possible losses on the gas circuit and gas valve
- Check of gas pressure at nozzle
- Overall control of all components of the heater
- Control of openings and ventilation systems (natural and/or mechanical)
- Control of alarm signals, if any

If the equipment is installed in dusty environments is advisable to clean more frequently the burners blowing compressed air at low pressure, working from holes in the flange / venturi pipe. In case the heater is running, shut it down and wait, before you blow, that it is cool.

9.0 Nozzle replacement

In case you need to change the type of gas for which the heater was prepared, you should contact MARK BV to get the specific transformation kit, specifying the model of heater, serial number and the new gas. The operations must be performed by qualified personnel and in compliance with the regulations.



IMPORTANT: If you change the nozzle to move to a different type of gas (f.e.: from natural gas G20 to LPG G30 or vice versa) it is compulsory to change also the plate label, placing a label with the new features, and put seal again after operation

For heaters with 4, 6, 8, 10 and 10+10 ceramic plates

- Use a CHI3 spanner to unscrew and take out the gas nozzle
- Screw properly new gas nozzle

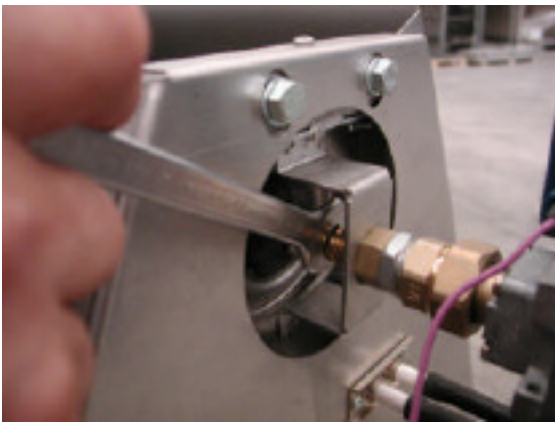

For heaters with 12, 16, 12+12 and 16+16 ceramic plates

- Unscrew the 3 screws (pos. 1) and take out the aluminium flange (pos. 2)
- Use a CHI3 spanner to unscrew and take out the gas nozzle (pos. 3)
- Screw properly new gas nozzle, mount the flange and screw blocking screws



10.0 Trouble shooting

TROUBLE		POSSIBLE CAUSE	SOLUTION
A - The heater turns on, the ignition electrode continues to sparkle, then goes to block	A1	Phase and Neutral with wrong connection	Check Phase / Neutral polarity and eart connection
	A2	The flame detection electrode is too far from the plates superfaces	Verify that the flame detection electrode is approx. 4 mm from the radiant surface
	A3	The control unit is defective	Replace the control unit
B - The heater turns on partially	B1	Insufficient gas flow	Check that gas supply has sufficient flow rate compared to gas consumption of the heater
	B2	Inlet gas pressure of the burner is too low	Check that the gas pressure corresponds to that shown on the plate label
	B3	Dirty nozzle	Clean nozzle with compressed air (NO mechanical device)
C - The burner does flash-back	C1	Inlet gas pressure of the burner is too high	Check that the gas pressure corresponds to that shown on the plate label
	C2	Burner or ceramic plates are dirty	After burner is cold, blow air at low pressure on the ceramic plates surface, from inside
	C3	Ceramic plates are cracked	Replace the ceramic plates
D - The heater doesn't turn because no gas is getting	D1	Interruption in the elctric plant	Verify voltage at connector of power supply
	D2	No tension	Replace the control unit
	D3	Solenoid valve is live, but coils are not energized	Replace the gas valve
E - The ignition electrode doesn't sparkle, and burner goes to block	E1	The electrode doesn't spark because of wrong distance between its tip and earth	Adjust distance (closer or further) between tip of ignition electrode and mass : should be 3 ÷ 4 mm
	E2	Power interruption	Check contacts connection of electrodes and control unit
	E3	The spark of the ignition electrode starts close to the ceramic protection, due to its breakcage, or between cable and mass	Replace the whole ignition and detection device, or just the cable, or just the electrode
F - The gas valve turns on, but the heater doesn't turn and goes to block	F1	Air in the gas pipe	Repeat the ignition cycle several times, waiting a time of approx. 20 sec between an ignition and the other
	F2	No gas	Verify that all devices of fuel interception, on gas pipeline, do not prevent passage

kiwa

Partner for progress



Numero / Number | 9100

Sostituisce / Replaces -

Emesso / Issued | 18/04/2008

Scopo / Scope

Directive 90/396/CEE

Rapporto / Report: 300965

Pag. 1 di 2

Kiwa Italia certifica che
Kiwa Italia hereby declares that
i prodotti riportati nelle pagine seguenti, commercializzati da
the products mentioned in the following pages, marketed by
MARK B.V.

di / in Veendam, Nederland

soddisfano i requisiti riportati nella

meet the essential requirements as described in the
Direttiva Apparecchi a Gas (90/396/CEE)
Directive on appliances burning gaseous fuels (90/396/CEE)
Kiwa Italia S.p.a.

 Adriaan Besemer
 Amministratore delegato

 È permessa la pubblicazione del certificato.
Publication of the certificate is allowed.
Kiwa Italia S.p.a.

 Sede Legale:
 Via G. Canducci, 5
 20123 Milano

 Sede Amministrativa e operativa:
 Via Trentino, 32/34
 21020 San Vendemiano (TN)

GASTEC
Notified Body
0694
CE



Product Conformity Certificate

Numero / Number | 9100 Sostituisce / Replaces -
 Emesso / issued | 18/04/2008 Scopo / Scope Direttiva 90/396/CEE

Rapporto / Report : 300965 Pag. 2 di 2

diffusori termici a gas ad irraggiamento luminoso, tipo non domestic overhead luminous radiant heaters, type

Marchio / trade mark

- Infra HT 4.2
- Infra HT 6.2
- Infra HT 8.2
- Infra HT 10.2
- Infra HT 4.2 High / Low
- Infra HT 6.2 High / Low
- Infra HT 8.2 High / Low
- Infra HT 10.2 High / Low
- Infra HT 4.2 eco
- Infra HT 6.2 eco
- Infra HT 8.2 eco
- Infra HT 10.2 eco
- Infra HE 4.2 eco High / Low
- Infra HE 6.2 eco High / Low
- Infra HE 8.2 eco High / Low
- Infra HE 10.2 eco High / Low
- Infra HE 4.2 DS
- Infra HE 6.2 DS
- Infra HE 8.2 DS
- Infra HT 10.2 DS
- Infra HT 4.2 DS High / Low

MARK Infra HT

- Infra HT 6.2 DS High / Low
- Infra HT 8.2 DS High / Low
- Infra HT 10.2 DS High / Low
- Infra HT 4.2 PEZO
- Infra HT 6.2 PEZO
- Infra HT 8.2 PEZO
- Infra HT 4.2 eco PEZO
- Infra HT 6.2 eco PEZO
- Infra HT 8.2 eco PEZO
- Infra HT 4.2 MD
- Infra HT 6.2 MD
- Infra HT 4.2 MR
- Infra HT 6.2 MR
- Infra HT 6.2 ST
- Infra HT 8.2 ST
- UPO HT C
- UPO HT 6 High/Low
- UPO HT M
- Infra HT 10+10.2
- Infra HT 10+10.2 eco

- Infra HT 10+10.2 High / Low
- Infra HT 10+10.2 eco High / Low
- Infra HT 12.2
- Infra HT 12.2 eco
- Infra HT 12.2 High / Low
- Infra HT 12.2 eco High / Low
- Infra HT 12x12.2
- Infra HT 12x12.2 eco
- Infra HT 12x12.2 High / Low
- Infra HT 12x12.2 eco High / Low
- Infra HT 12.2 DS
- Infra HT 12.2 DS High / Low
- Infra HT 16.2
- Infra HT 16.2 eco
- Infra HT 16.2 High / Low
- Infra HT 16.2 eco High / Low
- Infra HT 16x16.2
- Infra HT 16x16.2 eco
- Infra HT 16x16.2 High / Low
- Infra HT 16x16.2 eco High / Low

comercializzati da /

marketed by
di / in

MARK B.V.

Veendam, Nederland

NIP/ PN : 0694BS0965
 Rapporto / report : 300965
 Tipi di apparecchi / appliance type : A₁

I suddetti prodotti sono stati approvati per
 Mentioned products have been approved for

AL		AT		BE		BG	
CY		CZ		DE		DK	
EE		ES		FI		FR	
GB		GR		HU		E	
IS		IT		LT		LU	
IV		MK		MT		NL	
NO		PL		PT		RO	
SE		SI		TR		HR	
BH		BY		MD		UA	
YU		CH				SK	

Kiwa Italia S.p.a.

Sede legale:
Via G. Carrocci, 5
20123 Milano

Sede Amministrativa e operativa:
Via Tracchi, 32/34
31020 San Vendemiano (TV)

GASTEC

Notified Body

0694



DATE and STAMP

OPERATION / NOTES

DATE and STAMP

OPERATION / NOTES

DATE and STAMP

OPERATION / NOTES

DATE and STAMP

OPERATION / NOTES

DATE and STAMP

OPERATION / NOTES

MARK BV

BENEDEN VERLAAT 87-89
VEENDAM (NEDERLAND)
POSTBUS 13, 9640 AA VEENDAM
TELEFOON +31 (0)598 656600
FAX +31 (0)598 624584
info@mark.nl
www.mark.nl

MARK EIRE BV

COOLEA, MACROOM
CO. CORK
PI2W660 (IRELAND)
PHONE +353 (0)26 45334
FAX +353 (0)26 45383
sales@markeire.com
www.markeire.com

MARK BELGIUM b.v.b.a.

ENERGIELAAN 12
2950 KAPellen
(BELGIË/BELGIQUE)
TELEFOON +32 (0)3 6669254
info@markbelgium.be
www.markbelgium.be

MARK DEUTSCHLAND GmbH

MAX-PLANCK-STRASSE 16
46446 EMMERICH AM RHEIN
(DEUTSCHLAND)
TELEFON +49 (0)2822 97728-0
TELEFAX +49 (0)2822 97728-10
info@mark.de
www.mark.de

MARK POLSKA Sp. z o.o

UL. JASNOGÓRSKA 27
42-202 CZĘSTOCHOWA (POLSKA)
PHONE +48 34 3683443
FAX +48 34 3683553
info@markpolska.pl
www.markpolska.pl

MARK SRL ROMANIA

STR. BANEASA NO 8 (VIA STR. LIBERTATII)
540199 TÂRGU-MURES, JUD MURES
(ROMANIA)
TEL/FAX +40 (0)265-266.332
office@markromania.ro
www.markromania.ro

